

MSLICER

Meat Slicer Assembly & Operating Instructions



READ ALL INSTRUCTIONS AND WARNINGS BEFORE USING THIS PRODUCT.

This manual provides important information on proper operation & maintenance. Every effort has been made to ensure the accuracy of this manual. These instructions are not meant to cover every possible condition and situation that may occur. We reserve the right to change this product at any time without prior notice.

CALIFORNIA PROPOSITION 65 WARNING This product, or the exhaust from this generator, may contain chemicals, including lead, known to the State of California to cause cancer and birth defects or other reproductive harm. Wash hands after handling.

IF THERE IS ANY QUESTION ABOUT A CONDITION BEING SAFE OR UNSAFE, DO NOT OPERATE THIS PRODUCT!

HAVE QUESTIONS OR PROBLEMS? DO NOT RETURN THIS PRODUCT TO THE RETAILER - CONTACT CUSTOMER SERVICE.

If you experience a problem or need parts for this product, visit our website <http://www.buffalotools.com> or call our customer help line at **1-888-287-6981, Monday-Friday, 8 AM - 4 PM Central Time**. A copy of the sales receipt is required.

FOR CONSUMER USE ONLY – NOT FOR PROFESSIONAL USE.

KEEP THIS MANUAL, SALES RECEIPT & APPLICABLE WARRANTY FOR FUTURE REFERENCE.

RECOGNIZE SAFETY SYMBOLS, WORDS & LABELS



This is a safety alert symbol. It is used to alert you to potential personal injury hazards. Obey all safety messages that follow this symbol to avoid possible injury or death. WARNING indicates a potentially hazardous situation which, if not avoided, could result in death or serious injury.



READ AND UNDERSTAND ALL INSTRUCTIONS. Failure to follow all instructions may result in electric shock, fire and/or serious personal injury.

WHAT YOU NEED TO KNOW ABOUT SAFETY INSTRUCTIONS

The warning and safety instructions appearing in this manual are not meant to cover all possible conditions and situations that may occur. Common sense, caution and care must be exercised when operating or cleaning tools and equipment. Always contact your dealer, distributor, service agent or manufacturer about problems or conditions you do not understand before operating the product.

GENERAL PRODUCT SPECIFICATIONS

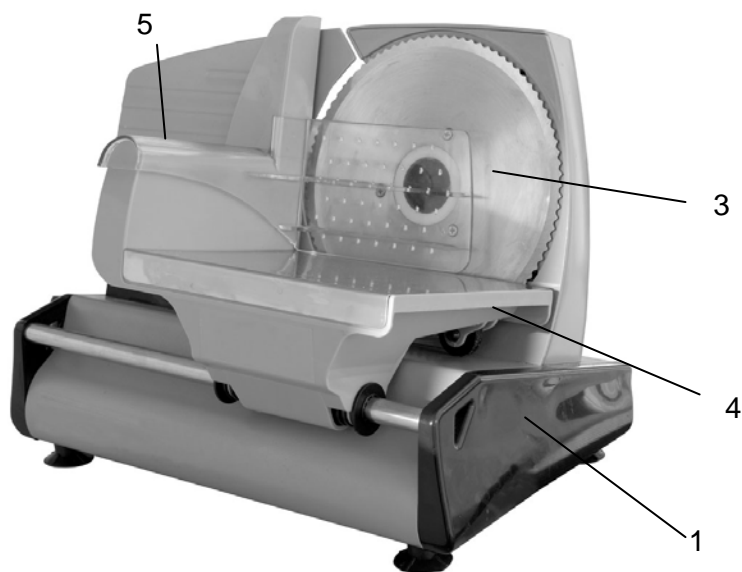

FEATURES

1. Housing
2. Power Switch
3. Cutting blade
4. Sliding food table
5. Handle
6. Slice Thickness Knob

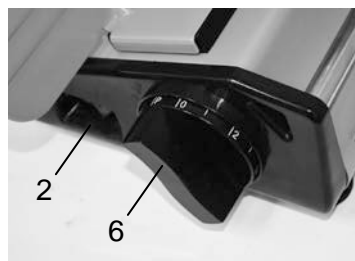

IMPORTANT SAFETY RULES

COMMON SENSE AND CAUTION ARE FACTORS WHICH CANNOT BE BUILT INTO ANY PRODUCT. THESE FACTORS MUST BE SUPPLIED BY THE OPERATOR.

WARNING

Keep the work area clean and well lit. A cluttered work area may cause accidents.

Never use this product near flammable liquids or gasses.

Never allow children to use this product without responsible adult supervision. When operating this product, keep children at a safe distance from the work area.

WARNING

Wear suitable clothing. Do not wear loose clothing or jewelry. They may get caught in moving parts.

Never wear rings with protruding parts. Wear a hat over long hair. Wear rubber footwear.

Always wear safety goggles and ear protection when using the product. Wear a dust mask when the work is dusty.

WARNING

Prevent electrical shock. Keep the power cord away from water, heat, oil, sharp edges and rough surfaces. Do not operate if power cord is frayed or damaged.

Never move the product while it is plugged into an electrical outlet. Make sure the switch is in the "OFF" position when the power cord is plugged-in.

Never carry the product by the power cord. Do not pull the power cord to remove the plug from sockets. Keep the power cord away from heat, oil and sharp edges.

Never use product in damp or wet conditions.

Never carry a plugged-in product with your finger on the switch. Always switch off the product and allow it to stop moving before putting it down.

This appliance has a polarized plug (one blade is wider than the other). This plug will fit in a polarized outlet only one way. If the plug does not fit the outlet perfectly, reverse the plug. If it should still not fit, contact a qualified electrician. To reduce the risk of electric shock, do not modify the plug in any way.

IMPORTANT SAFETY RULES (Continued)

WARNING

When not in use, store product in a secure, dry and safe place. The storage area should be lockable and out of the reach of children.

Use a product designed for the job being performed. Do not use low-powered products for heavy-duty operations. Never use the machine for anything other than its intended purpose.

Maintain this product with care. This product works best and safest if it is kept clean. Observe the instructions for maintenance and changing accessories. Keep dry and free of oil and grease.

WARNING

Use extension cords marked and rated for outdoor use. When using machines with a ground connection, an extension cord with a grounded connection should be used and connected to a grounded outlet.

Stay alert. Do not use this product when impaired by medicine, drugs, or alcohol. Watch what you are doing and use common sense for your safety.

Before starting the machine check that all safety devices and parts operate smoothly and efficiently. Make sure that all moving parts are in good working order. Check the machine for any broken parts. Make sure all parts are fitted properly and any other conditions that might affect the proper functioning of the machine are correct. Do not use the machine when it cannot be switched on or off.

WARNING

For your own safety, use only the accessories recommended in this manual.

Service must be performed by qualified repair personnel. Service or maintenance performed by unqualified personnel could result in a risk or injury.

When servicing a tool, use only identical replacement parts. Use of unauthorized parts or failure to follow maintenance instructions may create a risk of electric shock or injury

SAVE THE RECEIPT, WARRANTY AND THIS MANUAL. READ THE ENTIRE MANUAL TO BECOME FAMILIAR WITH THIS PRODUCT BEFORE YOU BEGIN USING IT.

When unpacking, check to make sure all parts are included. If any parts are missing or broken, please call Customer Service at 1-888-287-6981.

IMPORTANT SAFETY RULES (Continued)

The slicer must be connected to a 120V AC electricity supply only.

Before you clean the slicer, always turn off the power and pull the plug out of the socket.

For indoor use only. Never immerse the device in water and do not expose the device to rain or moisture. If the device should fall into water first pull the plug out of the socket and only then remove the device from the water. Afterwards have the slicer examined by an authorized service center before you use it.

Do not use the slicer if your hands are wet or if you are standing on a wet floor. Do not use the slicer if it is wet or moist.

Set up and store the slicer out of reach of children. Do not leave the slicer unattended.

The slicer should always be used with the sliding feed table and handle in position. Do not use the slicer to slice through bones or deep-frozen food.

Do not use the slicer if it is damaged in any way. Have the slicer immediately repaired at an authorized service center or other suitably qualified repairer.

Use the slicer with the supplied accessories only.

PROPER USE

This device is intended for slicing normal household foods. The food to be sliced must be thawed, unpacked and free from bones before it can be sliced in the device.

Any other use or modification to the equipment shall be considered as improper use and could cause considerable danger.

Nominal Voltage: 120V- 60Hz

Power Rating: 180W

Cutting Blade: reinforced, non-rusting fine blade, 7.5"

Continuous Operation Time is 10 min

110 RPM

Maximum Slicing Thickness: 9/16"

SETTING UP THE SLICER

⚠ WARNING

Before and after use, wash all parts with warm soapy water. Cutting knives are sharp! Use care when using the product and when cleaning the product to prevent injury.

Never place the slicer on a hot surface or near an open flame.

Make sure that the power cord does not pass over hot or sharp edged objects.

Do not allow the power cord to become kinked or trapped and do not wind it around the slicer.

Take the slicer carefully out of its packaging. Remove all the packaging material and keep it together with the packaging. Clean the slicer before it comes into contact with any food.

Place the slicer on a flat, non-slip surface close to an electrical socket.

Unwind the length of power cord. Insert the plug into the electrical socket. Push the piece holder onto the sliding feed table.

SLICING

Never touch the blade when the slicer is operating! Use the slicer only for slicing normal household foods and not for other purposes. Do not use the slicer for slicing deep-frozen foods, bones, foods with large kernels or for slicing packaged foods. Never use the slicer for more than 10 minutes at a time.

REMOVING THE CUTTING BLADE

Use a screwdriver to remove the three small screws around the center of the blade. When removing the blade, be sure to handle it by the center and avoid the outer sharp edge. Wash the blade by hand in warm water with dishwashing liquid (do not place in the dish washer). Clean the housing behind the blade with a dry cloth or a soft brush.

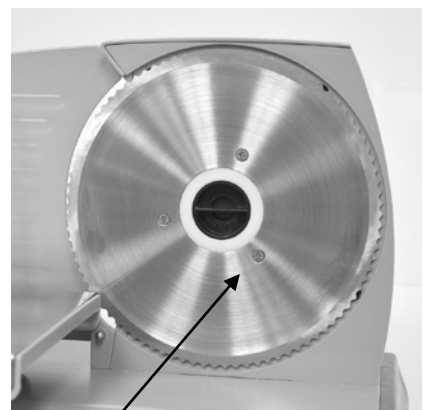

Screw

RUNNING THE SLICER

⚠ WARNING

The cutting blade continues to rotate after the slicer has been switched off. Use caution when operating the slicer and/or removing the blade. For safety, the slice thickness should be returned to the "0" setting after each use.

Pushing the switch to "ON" will allow the cutting blade to run. Move the switch quickly into the "OFF" position and wait until the cutting blade comes to a complete standstill before attempting to move the slicer or removing the material being sliced.

SETTING THE SLICE THICKNESS

The slice thickness can be set to between 0 and approx. 0.60". Set the required slice thickness using the knob (6). The settings on the scale do not correspond with the slice thickness.



Place the food to be sliced on to the sliding feed table. Press the food to be sliced with the holder lightly against the food plate. Switch the device on. While lightly pressing the food to be sliced forward, using only the food holder, NOT your fingers, guide it along the cutting blade. After using the slicer always set the food support plate into the neutral setting (by sliding the food support plate to the right) so that the sharp blade is covered. To safeguard your fingers always use the sliding feed table and the piece holder.

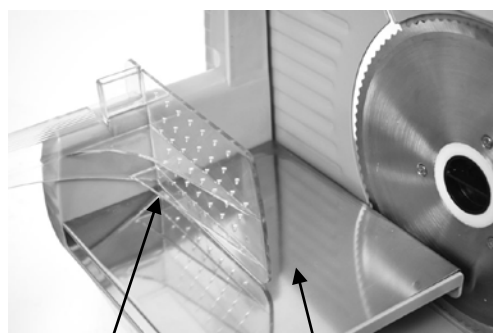

Food holder

Sliding food table

⚠ WARNING

Before using, wash all parts with warm soapy water. Blade is sharp! Use care when handling the product and when cleaning the product to prevent injury. Do not immerse the slicer in water.

Before starting to clean the slicer, switch it off, pull the plug out of the electrical socket and set the food support plate into the neutral setting. It is necessary to clean the slicer at regular intervals as perishable food scraps could accumulate on the slicer or behind the cutting blade. Remove the piece holder and clean it in warm water and dishwashing liquid (do not place in the dishwasher).

Wipe the housing and sliding food table using a slightly damp cloth. Do not use harsh or abrasive cleaners, scouring pads or hard brushes. Rinse all removable parts with clear hot water and allow them to dry before placing back on the slicer. Wipe slicer unit clean with a damp cloth.

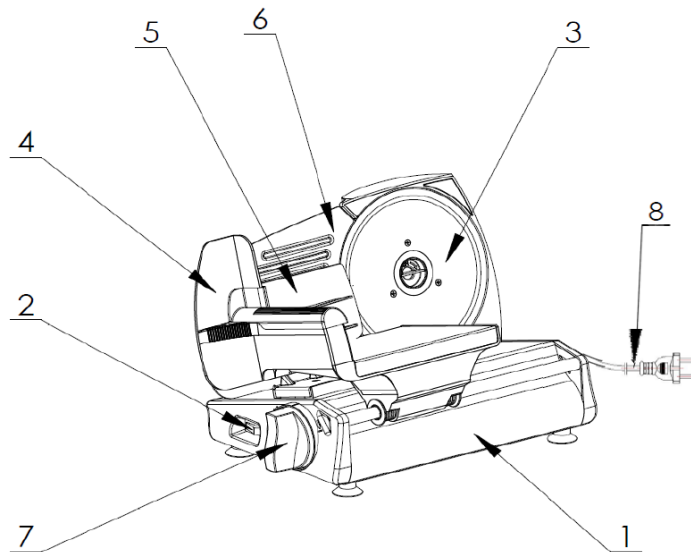
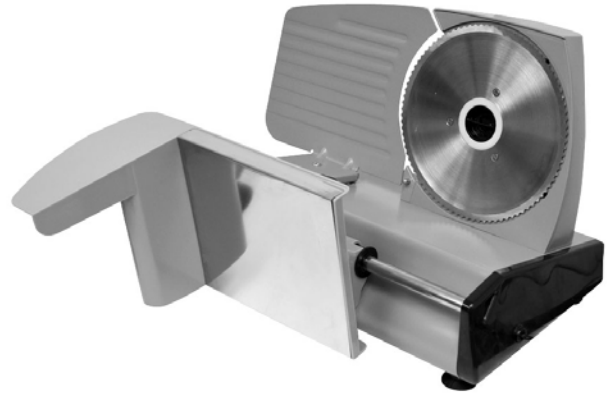

Parts List / Parts Diagram

Part#	Description	Qty.	Part#	Description	Qty.
1	Housing	1	5	piece holder	1
2	Switch	1	6	Food support plate	1
3	Cutting Blade	1	7	Knob for slice thickness	1
4	Sliding feed table	1	8	plug	1